

Model SL33A

Formed Steel Louver • 6" Deep • 45° Drainable Blades • Adjustable • Galvanized Steel

STANDARD CONSTRUCTION

- FRAME:** 18-GA. galvanized steel.
- BLADE:** 18-GA. galvanized steel, open to 45°.
- AXLES:** 1/2" dia. extruded aluminum "pin-lock" rod with "double-sealed" bearings.

- CONSTRUCTION:** Welded and/or riveted for maximum service.
- LINKAGE:** Concealed in one jamb out of airstream, up to 48" width.
- SEALS:** Stainless steel at jambs.
- SCREEN:** (when indicated, specify interior or exterior)
1/2" sq. mesh, 19-GA. galvanized steel, .041".
- FINISH:** Mill.

OPTIONS

- Frames and Blades of other gauges
- Other materials - Stainless steel, Copper, Aluminum, etc.
- Neoprene blade edge seals
- Finishes - Enamels, Epoxies, etc.
- Screens - Insect screen 1/16" aluminum mesh, .011",
-or- 1/2" flattened aluminum, .051",
-or- 1/4" sq. mesh, 18-GA galvanized steel, .047",
-or- 1/2" sq. mesh, 18-GA stainless steel, .047",
And others.

NOTES

1. Nominal deductions will be made to the opening size given.
2. Approximate shipping weight is 8.0 lbs./sq.ft.

LOUVER SIZES

Min Panel	Max Single Panel
12"W x 12"H	60"W x 96"H

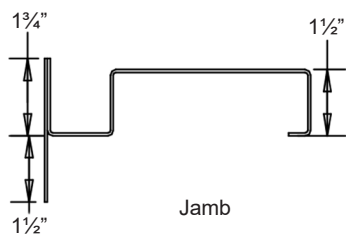
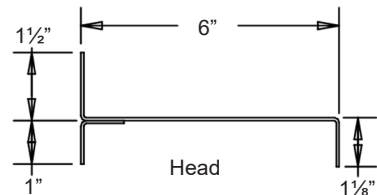

Flange Frame available

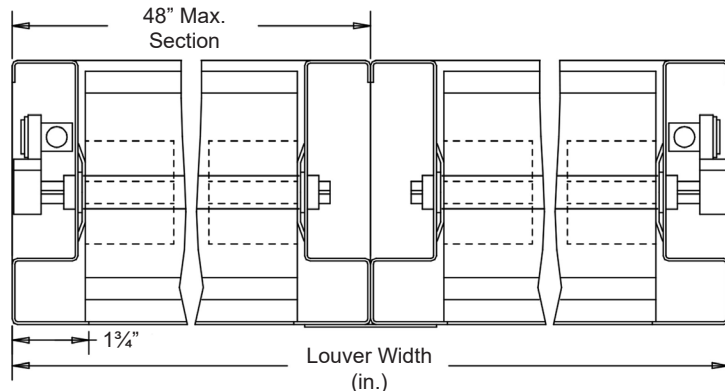
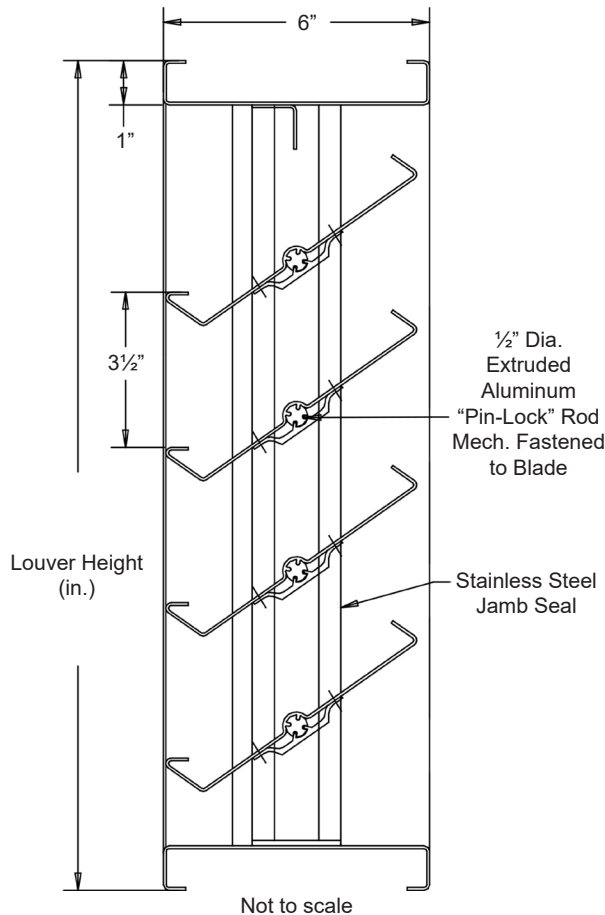

Item #	Qty	Width	Height	Width	Height	Mullion	Type	Location
		Opening Size		Louver Size			Screens	
Arch. / Eng. :						EDR:	ECN:	Job:
Contractor:								
Project:						Date:	DWN:	DWG:

In the interest of product development, Louvers & Dampers reserves the right to make changes without notice.



Model SL33A

Formed Steel Louver • 6" Deep • 45° Drainable Blades • Adjustable • Galvanized Steel

PERFORMANCE DATA

Pressure Drop: .18 in. w.g. at 1200 fpm
 Free Area: 8.50 sq.ft. = 53% for 48"W x 48"H sample tested in accordance with AMCA Standard 500-L.
 Beginning Point of Water Penetration: 859 (fpm)

Ratings do not include the effects of a bird screen.

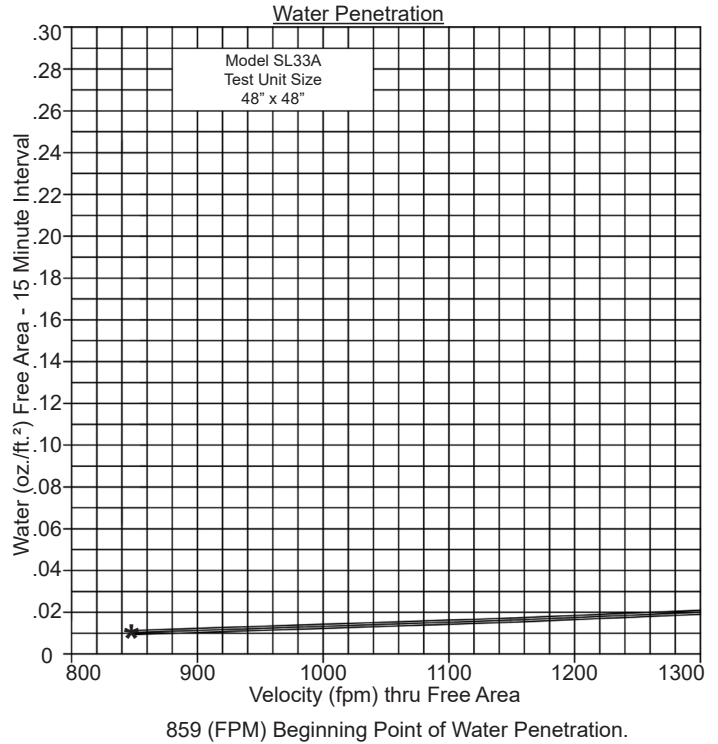
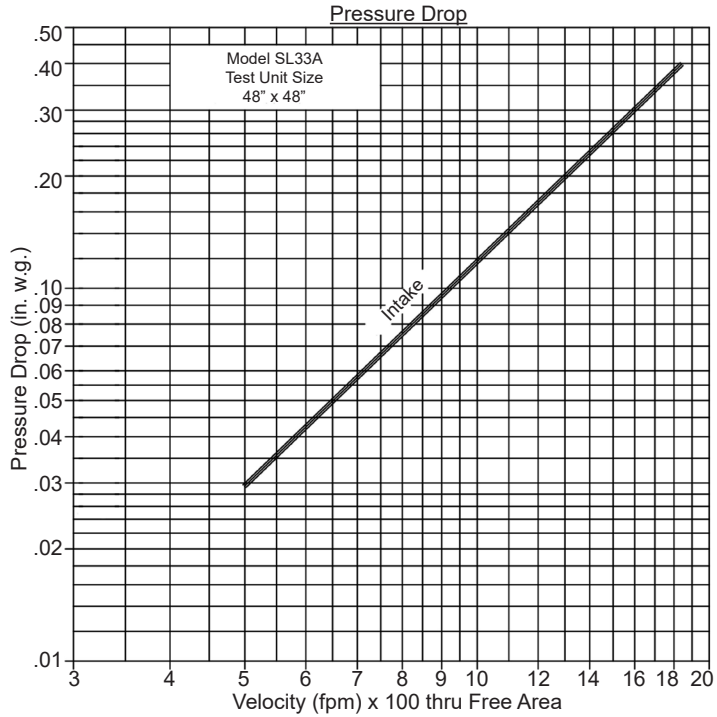

Intake air converted to standard air density.
 Tested to AMCA Standard 500-L, Figure 5.5.

		Free Area (sq. ft.)								
		Width (in.)								
		12"	18"	24"	30"	36"	42"	48"	54"	60"
Height (in.)	12"	.31	.51	.71	.91	1.10	1.30	1.50	1.66	1.89
	24"	.75	1.21	1.67	2.14	2.61	3.07	3.54	4.01	4.47
	36"	1.27	2.05	2.84	3.64	4.43	5.23	6.02	6.81	7.61
	48"	1.73	2.90	4.02	5.14	6.26	7.38	8.50	9.62	10.74
	60"	2.23	3.59	4.98	6.37	7.76	9.15	10.54	11.93	13.32
	72"	2.72	4.44	6.15	7.87	9.58	11.30	13.02	14.74	16.46
	84"	3.19	5.13	7.12	9.10	11.09	13.08	15.06	17.05	19.04
	96"	3.71	5.98	8.29	10.60	12.92	15.23	17.54	19.86	22.17